

IBL 3000



The IBL3000 was developed in close co-operation with a customer, who had specific needs for operating a dry ice blaster in an environment with many challenges. Size and simplicity combined with the known strength and durability of the IBL4000 were the key facts.

The intelligent choice!

IBL 3000

With an overall width of only 400 mm the machine can easily be moved in and around in narrow spaces and especially in between machines in the production. This enables the operator to get closer to the point of cleaning and thereby being able to work with shorter length of blast hoses, which again gives a better cleaning result.

Hopper capacity

Being narrower does not mean a smaller dry ice hopper. Like the IBL4000 the IBL3000 holds more than 25 kgs of dry ice, which for most applications is more than 30 minutes operation before refilling. The hopper is not removable for emptying dry ice back into the dry ice container, but can be dismantled in less than 10 minutes for service at the machine.

Simplicity and robustness

Operating and moving equipment around in tight spaces also means a risk of damage to the machine. That is why we have designed the operation of the equipment with components that are not sticking far out (risk of breaking off) and at the same time all components are placed protected behind the handles at the back of the machine.

Price matters

Another parameter of course is price. Compared to the IBL4000 we have designed the IBL3000 without the toolbox or the remote control of dry ice flow and pressure on the gun (can be ordered as option) and it only comes with the short nozzle including 3 inserts as standard.

Well known advantages

The IBL3000 of course has all the features that are known from the IBL4000. Large flat free tires, true 1 inch air flow through all parts, all FESTO components and 7 meter hose of your choice (lightweight PU or technical rubber).

Dimensions:

Width: 400 mm
Height: 1110 mm
Length: 780 mm
Weight: 80 kg

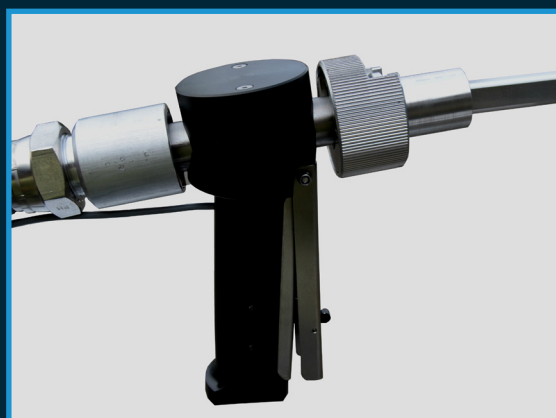

INTELblast Denmark
Birkevangsvej 2
5466 Asperup
Denmark

Phone: +45 70 25 90 10
Mail: info@INTELblast.com